

# SIMPLE MACHINES

## Worksheet 2

*A worksheet produced by the Native Access to Engineering Programme*



## What is a machine?

*Webster's Dictionary defines a machine as*

- 1. a structure consisting of a framework and various fixed and moving parts, for doing some kind of work;*
- ...*
- 8. a device that transmits, or changes, the application of energy.*

There are many different types of machines.

Some are very large and complex like the Canada Arm on the space shuttle

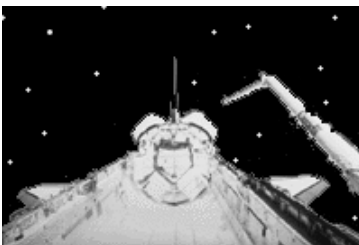

Some are very small and complex, like cellular phones.



*Some scientists think one day we will be able to make microscopic nanomachines which will be small enough to float around in our blood streams and repair damaged cells!*

In the age of computers, cellular phones and satellite dishes, we have come to expect machines to be very complex objects, but in reality machines can be very simple. In fact, there are six basic "simple machines" which people have used since ancient times to make their work easier.

# The simple machines

The six simple machines are:

the lever,



the pulley,

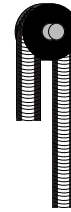

the wheel and axle,



the inclined plane,

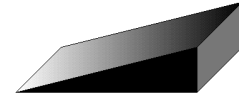

the wedge



and the screw.



*Can you think of ways in which each of these machines could be used?*

Each of the simple machines can be used as a machine by itself, or can be combined with other simple machines to make more complex machines.

Machines are used by all types of engineers, but are generally designed by mechanical engineers.

## Why are simple machines important?

Simple machines are important for two reasons:

1. They allow you to change the direction of an applied force. For example, if you are lifting a weight with a pulley, you apply a force downwards as you pull on the rope, but the weight you are pulling moves up.

As you pull down...

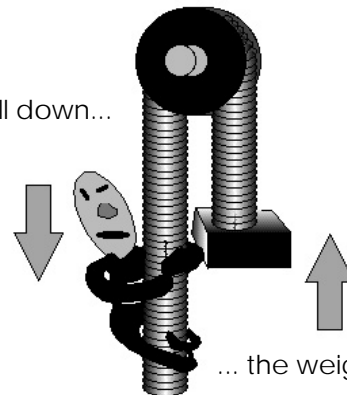

... the weight moves up.

2. They also allow you to accomplish a task by doing less work.

*What do you think work is?*

# Work and energy

Work is the causing of motion against a resisting force. In other words, it is the amount of effort which has to be exerted in order to get an object to move.

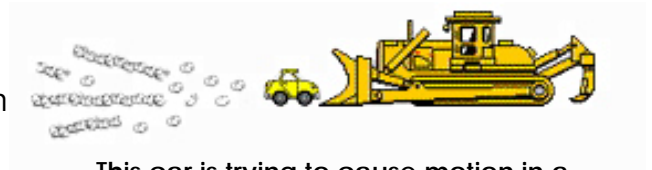

This car is trying to cause motion in a very large resisting force (the bulldozer).

For engineers, work is related not only to effort (or force) but also to distance. The force (F) is the effort you use to move an object and the distance (D) is the distance over which you exert the effort. Work is calculated by the following formula.

$$W(\text{ork}) = F(\text{orce}) \times D(\text{istance}).$$

	Units
Force	Newtons (N)
Distance	meters (m)
Work	Newton.meters (N.m) or Joules (J)

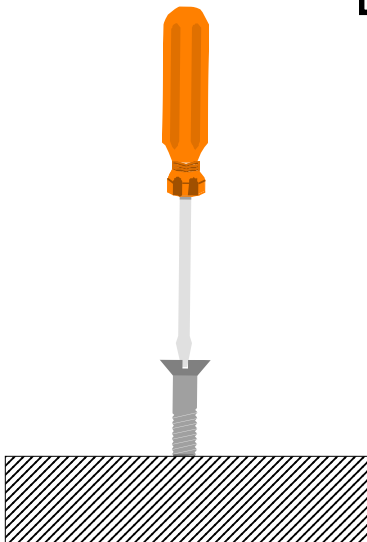

When work gets done energy is transferred from one system to another. Energy is the capacity for doing work. You must have energy to do work and the more energy you have, the more work you can do. Cars, snowmobiles and bulldozers get their energy from gasoline or other fuels. They can do lots of work as long as there is fuel available.

Energy is also needed to make simple machines work.

*Where do you think the energy comes from for most simple machines?*

## Aboriginal simple machines

Many of the tools which have been traditionally been used by Aboriginal peoples are simple machines.

*Do you know what some of these tools are?  
Can you think why it was important for people to develop simple machines?*

The engineering of tools in traditional Aboriginal communities was essential for survival. Tools help people to work more efficiently. Without the tools, more physical energy would be needed to complete a task. People get their energy from food - a resource which can be scarce at certain times during the year. Think about what this means.

Trying to complete a task like removing flesh from an animal skin without the help of a tool would take a lot more time and energy. By using a tool like a flesher (which is actually a wedge) a person could complete a task quicker and use less energy doing it. So the use of tools in traditional communities not only helped the person doing the work, it helped the entire community by conserving food.



Source: Old Crow - Caribou  
<http://www.schoolnet.ca/collections/english/index.htm>

Many other tools were (and are still) used in Aboriginal communities.



Source: Bone Snowknives and Tin Oil Lamps  
<http://xist.com/ROM-MCQ/E/index.htm>

Hammers, which are a type of lever, are used for a number of tasks including pounding nails and tenderizing meat. Can you think why stone hammers would be more effective than bone hammers?



Source: Bone Snowknives and Tin Oil Lamps  
<http://xist.com/ROM-MCQ/E/index.htm>

Canoe paddles are also levers. They are highly engineered tools which are designed to be very efficient. Paddles provide maximum push with minimum weight. Can you think how this is done?



Source: National Museum of Civilization  
<http://www.schoolnet.ca/collections/stones/engfrm.htm>

Other tools include fire drills (a type of pulley), drum sticks (levers), carving tools (wedges) and earth ramps (inclined planes) which have traditionally been used to raise huge log roof beams used in community buildings on the West Coast.

*Traditional Aboriginal practice is to use every part of a kill. Some animals like moose, deer, bear and walrus are very large and heavy. Whether the animal is butchered on site or not, every bit of it has to be brought back to the camp. How have or how could simple machines be used to make this task easier?*

# Work, force and distance

One of the laws of nature is that if you have to lift a 5kg rock 3m, it will always take the same amount of work no matter what. In other words the amount of work required to do any specific task is always the same. There is nothing you can do to make the work any less. But there is something you can do to lessen the amount of force or effort you have to exert in order to do that work. Can you figure out what it is?

Hint: Think about work always being the same for a specific task, look at the formula and try filling in the shaded spaces in the table .

Work (constant)	=	Force (effort)	x	Distance
24 N.m	=	1N	x	24m
24 N.m	=	2N	x	
24 N.m	=		x	8m
	=	4N	x	6m

There is a relationship between the force exerted and the distance over which it is exerted. For the same amount of work, as you increase the force, the distance over which you exert the force is decreased. In other words more force, less distance. So, to lower your force you have to increase the distance over which you apply it - or less force, more distance.

*Simple machines work based on the simple relationship as distance increases, force decreases.*

## References

### Books

1. Gradwell, John, Malcolm Welch and Eugene Martin. *Technology: Shaping Our World*, 1993, (Goodheart Willcox Company, Inc., Illinois)
2. Macaulay, David. *The Way Things Work*, 1988 (Houghton Mifflin Company, Boston)
3. McGrath, Susan. *Fun with Physics*, 1986 (National Geographic Society)

### Online

1. Bone Snowknives and Tin Oil Lamps: Enduring Tradition Among Canada's First Peoples  
<http://xist.com/ROM-MCQ/E/index.htm>
2. Bill Nye the Science Guy  
<http://nyelabs.kets.org>
3. Energy and Machines  
<http://www.sasked.gov.sk.ca/docs/mid1sci/gr8uhmsc.html>
4. Native SchoolNet  
<http://www.schoolnet.ca/ext/aboriginal>
5. Source: National Museum of Civilization  
<http://www.schoolnet.ca/collections/stones/engfrm.htm>
6. Old Crow - Caribou  
<http://www.schoolnet.ca/collections/english/index.htm>

# Math Problems

1. You are a local contractor building a house for a client on the edge of sheer hill. The hill is 5m above the nearest access road. There is no other way on to the site except up the sheer face of the hill. You need to get all your workers, building materials and equipment up the hill. You decide the easiest way to do this is to build a ramp out of earth. (A ramp is an inclined plane.) You can take a maximum load of 5000N up the ramp each time.

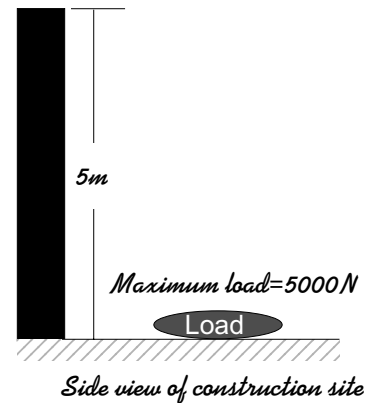

- What is the maximum amount of work you do with each load?
- If your ramp is 10m long, how much force do you need to apply to get the maximum load up to the top of the hill?
- How far away from the base of the hill should your ramp begin? (Calculate the length to the nearest centimeter.)
- Before you construct the ramp you have to know how much earth will be needed. The ramp is 2m wide. How much earth do you need?

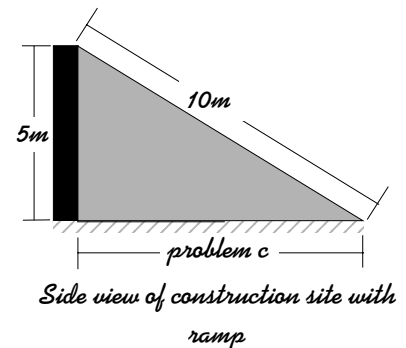

2. Your school has just received a new shipment of school supplies. You have agreed to help your teacher store them until they are needed. Unfortunately, the boxes are very heavy and you could seriously hurt your back trying to lift them onto the shelves. Luckily, your teachers has just taught you about simple machines, so you build a lever to help you with your task. Each box you are lifting weighs 100N, you need to lift them up 1m.

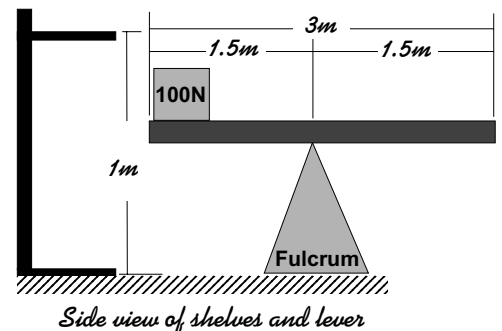

- How much work will you do to lift each box.
- If you use the lever as shown, you will have to exert 100N of force for each box you lift. You have about 50 boxes to lift and being a bit lazy you'd like to use less effort for each box. The plank you are using for the lever is 3m long, it can easily be moved back and forth along the fulcrum so that you can adjust the distance,  $x$ , at which you will apply your force.

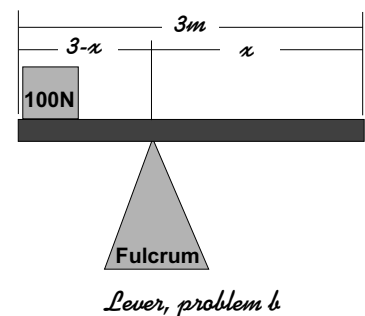

- Where should the fulcrum be placed so that you can use only 50N of force to lift the box?  
 What about if you wanted to use only 25N of effort for each box?
- Engineers are always concerned about the difference between what is theoretically possible and what can actually be done. Do you think it is practically possible to lift the boxes using only 50N or 25N. Why or why not?